

# Easy Drain<sup>®</sup>

by ess

## Compact Clean 50 FF Tile

Compact Clean is the world's flattest shower drain (making it perfect for renovation projects) and it requires almost no cleaning! Thanks to its improved siphon with our Dryphon<sup>®</sup> technology, it is now more powerful and convenient.

### FEATURES

- Available lengths - 500 - 1200 mm
- Water Protection System - 10-year warranty
- Siphon - Easy to clean
- Suitable for - Renovation projects
- Supplied as - Complete set
- Dryphon<sup>®</sup> technology - More power - less cleaning



#### Manufacturer

Easy Sanitary Solutions  
Nijverheidsstraat 60 | 7575 BK Oldenzaal | The Netherlands  
T. +31 (0)541 200 800 | F. +31 (0)541 200 899  
info@esspost.com | www.easydrain.com

#### Contact

Easy Sanitary Solutions  
Nijverheidsstraat 60 | 7575 BK Oldenzaal | The Netherlands  
T. +31 (0)541 200 800 | F. +31 (0)541 200 899  
sales@esspost.com | www.easydrain.com

## GENERAL

Serie	Compact FF
Name	Compact Clean 50 FF Tile
Model	Rectangular shower drain
Length (mm)	500, 600, 700, 800, 900, 1000, 1100, 1200
Product type	Complete
Application	Renovation
Certification	DIN 18534, ETAG-022

## INSTALLATION

Substrate	Lewis sheets, Concrete / Sand Cement, Wooden floors
Floor finish	Glass Mosaic, Tiles / Mosaic, Thin tiles
Height adjustable feet	Included
Installation option	Wall, Floor
Outlet	Horizontal
Connection (mm)	N.A.
Min. installation depth (mm) (built-in set)	68
Min. installation depth (mm) (incl. grate)	93

## DRAINAGE

Max. drainage capacity entrance (l/min)	34 (50 mm), 54 (Dryphon)
Max. drainage capacity wall (l/min)	36.5 (50 mm), 60 (Dryphon)
Max. drainage capacity (l/min)	36.5 (50 mm), 60 (Dryphon)

## BUILT-IN SET

Pre-assembled sealing membrane	Included
Siphon features	Cleanable
Water seal height (mm)	50
Outlet	Horizontal
Material siphon	Polypropylene (PP)

## DESIGN

Grate finish	Brushed stainless steel / Tile
Grate pattern	Zero / Closed
Grate width (mm)	45
Grate tile insert (mm)	12
Adjustable grate	No
Frame type	N.A.
TAF Frame material	N.A.
Design frame finish	N.A.
Frame width (mm)	N.A.
Wheelchair accessible	
Extension set available	N.A.



### Manufacturer

Easy Sanitary Solutions  
 Nijverheidsstraat 60 | 7575 BK Oldenzaal | The Netherlands  
 T. +31 (0)541 200 800 | F. +31 (0)541 200 899  
 info@esspost.com | www.easydrain.com

### Contact

Easy Sanitary Solutions  
 Nijverheidsstraat 60 | 7575 BK Oldenzaal | The Netherlands  
 T. +31 (0)541 200 800 | F. +31 (0)541 200 899  
 sales@esspost.com | www.easydrain.com

## ARTICLE CODE

500 mm	EDCLEANCOMTFF500-50		
600 mm	EDCLEANCOMTFF600-50		
700 mm	EDCLEANCOMTFF700-50		
800 mm	EDCLEANCOMTFF800-50		
900 mm	EDCLEANCOMTFF900-50		
1000 mm	EDCLEANCOMTFF1000-50		
1100 mm	EDCLEANCOMTFF1100-50		
1200 mm	EDCLEANCOMTFF1200-50		

## TECHNICAL DRAWINGS

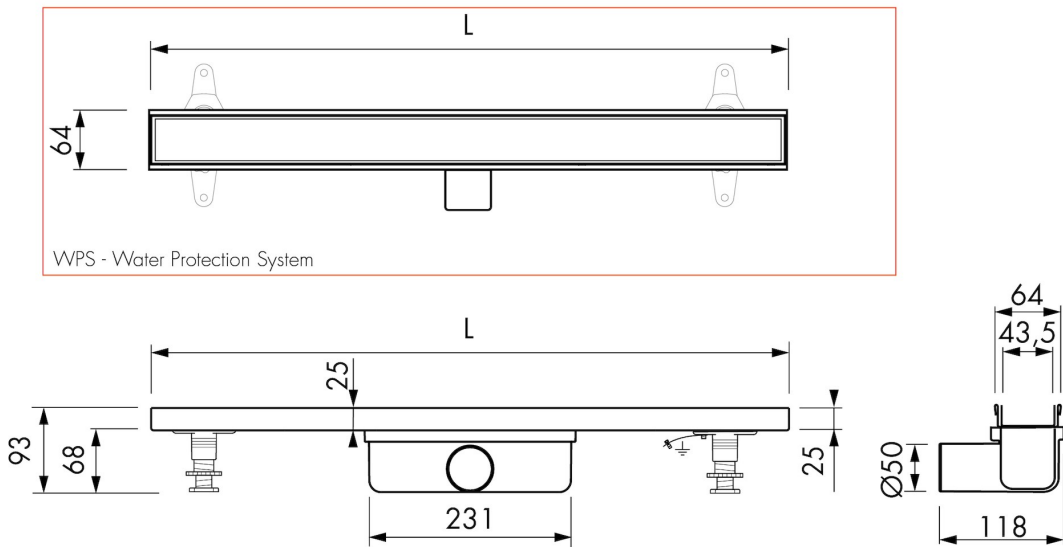

**Manufacturer**

Easy Sanitary Solutions  
 Nijverheidsstraat 60 | 7575 BK Oldenzaal | The Netherlands  
 T. +31 (0)541 200 800 | F. +31 (0)541 200 899  
 info@esspost.com | www.easydrain.com

**Contact**

Easy Sanitary Solutions  
 Nijverheidsstraat 60 | 7575 BK Oldenzaal | The Netherlands  
 T. +31 (0)541 200 800 | F. +31 (0)541 200 899  
 sales@esspost.com | www.easydrain.com