

Easy Drain®  
by ess

## Compact 30 FF | Tile

Easy Drain Compact, the flattest linear shower drain in the world, is supplied as standard with an easy-to-clean water seal with inspection cover for simple access to the connection drainage pipe. The Compact FF has a pre-assembled sealing membrane with a width of approximate 10 centimeters, to guarantee a waterproof finish.

### FEATURES

- Installation depth - Starting from 63 mm
- Siphon - Easy to clean
- Suitable for - Renovation projects
- Supplied as - Complete set
- Water Protection System - 10-year warranty
- Available lengths - 500 - 2000 mm



#### Manufacturer

Easy Sanitary Solutions  
Nijverheidsstraat 60 | 7575 BK Oldenzaal | The Netherlands  
T. +31 (0)541 200 800 | F. +31 (0)541 200 899  
info@esspost.com | www.easydrain.com

#### Contact

Easy Sanitary Solutions  
Nijverheidsstraat 60 | 7575 BK Oldenzaal | The Netherlands  
T. +31 (0)541 200 800 | F. +31 (0)541 200 899  
sales@esspost.com | www.easydrain.com

## GENERAL

Serie	Compact FF
Name	Compact 30 FF   Tile
Model	Rectangular shower drain
Length (mm)	500, 600, 700, 800, 900, 1000, 1100, 1200, 1300, 1400, 1500, 1600, 1700, 1800, 1900, 2000
Product type	Complete
Application	Renovation
Certification	ETAG-022, DIN 18534

## INSTALLATION

Substrate	Concrete / Sand Cement, Wooden floors, Lewis sheets
Floor finish	Tiles / Mosaic, Glass Mosaic, Thin tiles
Height adjustable feet	Excluded
Installation option	Floor
Outlet	Horizontal
Connection (mm)	40
Min. installation depth (mm) (built-in set)	43
Min. installation depth (mm) (incl. grate)	73

## DRAINAGE

Max. drainage capacity entrance (l/min)	25
Max. drainage capacity wall (l/min)	32
Max. drainage capacity (l/min)	32

## BUILT-IN SET

Pre-assembled sealing membrane	Included
Siphon features	Cleanable
Water seal height (mm)	30
Outlet	Horizontal
Material siphon	Polypropylene (PP)

## DESIGN

Grate finish	Tile
Grate pattern	Zero / Closed
Grate width (mm)	45
Grate tile insert (mm)	12
Adjustable grate	No
Frame type	N.A.
TAF Frame material	N.A.
Design frame finish	N.A.
Frame width (mm)	N.A.
Wheelchair accessible	Yes
Extension set available	No



### Manufacturer

Easy Sanitary Solutions  
 Nijverheidsstraat 60 | 7575 BK Oldenzaal | The Netherlands  
 T. +31 (0)541 200 800 | F. +31 (0)541 200 899  
 info@esspost.com | www.easydrain.com

### Contact

Easy Sanitary Solutions  
 Nijverheidsstraat 60 | 7575 BK Oldenzaal | The Netherlands  
 T. +31 (0)541 200 800 | F. +31 (0)541 200 899  
 sales@esspost.com | www.easydrain.com

## ARTICLE CODE

500 mm	EDCOMTFF 500-30	1300 mm	EDCOMTFF 1300-30
600 mm	EDCOMTFF 600-30	1400 mm	EDCOMTFF 1400-30
700 mm	EDCOMTFF 700-30	1500 mm	EDCOMTFF 1500-30
800 mm	EDCOMTFF 800-30	1600 mm	EDCOMTFF 1600-30
900 mm	EDCOMTFF 900-30	1700 mm	EDCOMTFF 1700-30
1000 mm	EDCOMTFF 1000-30	1800 mm	EDCOMTFF 1800-30
1100 mm	EDCOMTFF 1100-30	1900 mm	EDCOMTFF 1900-30
1200 mm	EDCOMTFF 1200-30	2000 mm	EDCOMTFF 2000-30

## TECHNICAL DRAWINGS

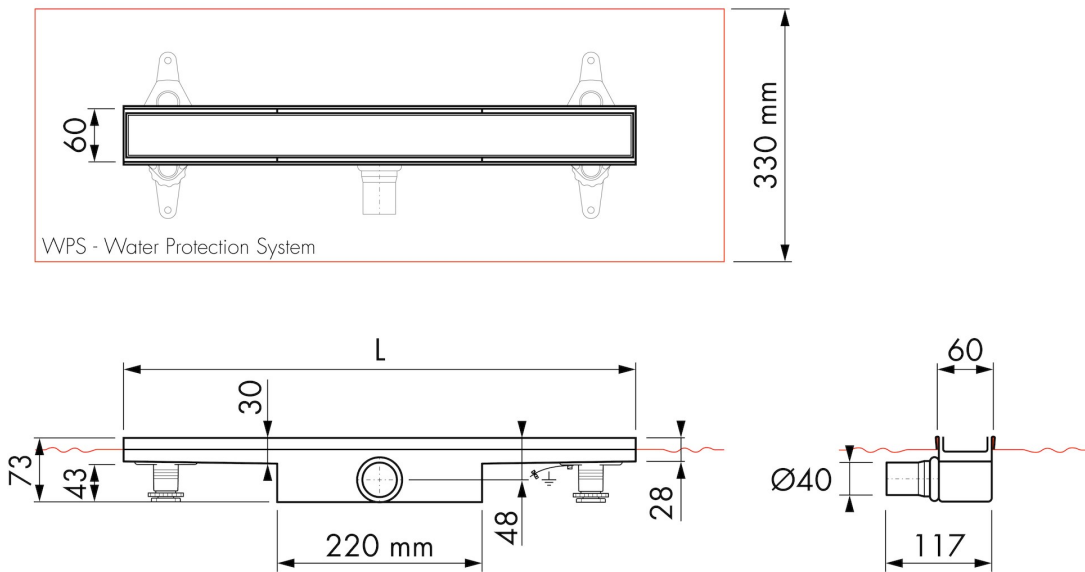

### Manufacturer

Easy Sanitary Solutions  
 Nijverheidsstraat 60 | 7575 BK Oldenzaal | The Netherlands  
 T. +31 (0)541 200 800 | F. +31 (0)541 200 899  
 info@esspost.com | www.easydrain.com

### Contact

Easy Sanitary Solutions  
 Nijverheidsstraat 60 | 7575 BK Oldenzaal | The Netherlands  
 T. +31 (0)541 200 800 | F. +31 (0)541 200 899  
 sales@esspost.com | www.easydrain.com